

# RANGE SERVANT®

<http://www.rangeservant.com>

## BALL DISPENSER ULTIMA-45

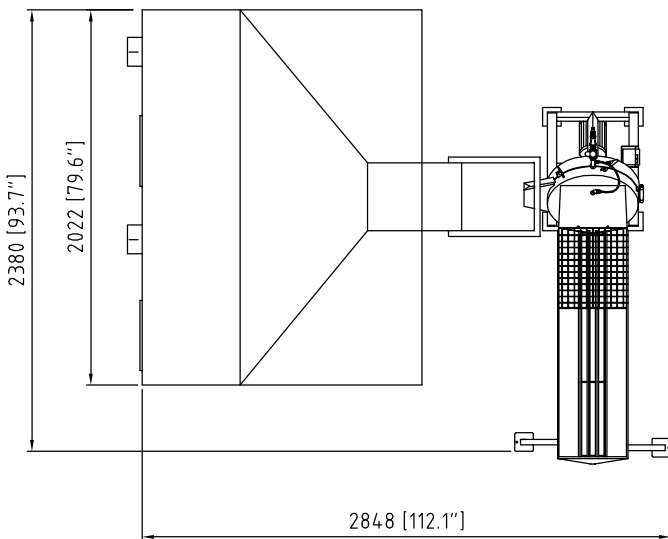
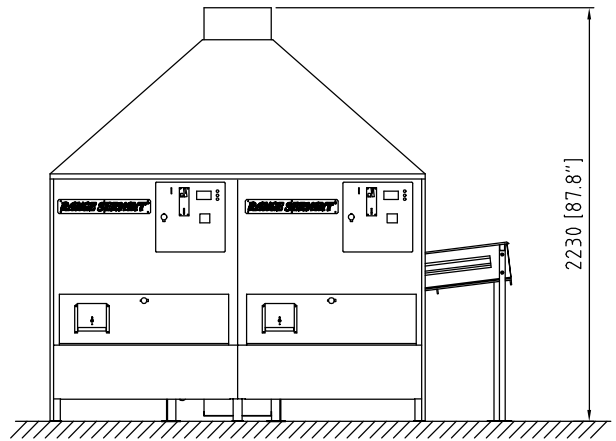
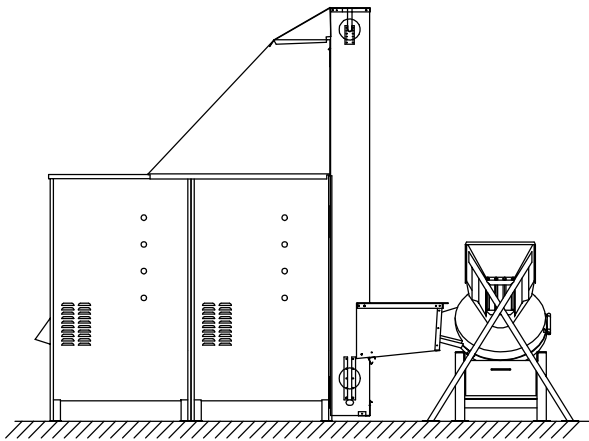

### ELEVATOR

CAPACITY	500 BALLS/MIN
MOTOR	0.18 KW
VOLTAGE	230 V, 50 HZ

### BALL DISPENSER

HOPPER CAPACITY	43 000 BALLS
DELIVERY CAPACITY	500 BALLS/MIN
SETTINGS	1-999 BALLS
WEIGHT	- KG
VOLTAGE	230 V, 50 HZ
MOTORS	2x17W AND 2x8W

### BALL WASHER

HOPPER CAPACITY	1,000 BALLS
WASHING CAPACITY	400 BALLS/MIN
MOTOR	0.55 KW
VOLTAGE	230 V, 50 HZ
PLUMBING CONNECTION	R 1/2"
WATER CONSUMPTION	4 L/MIN