

RANGE SERVANT®

<http://www.rangeservant.com>

BALL DISPENSER ULTIMA-12

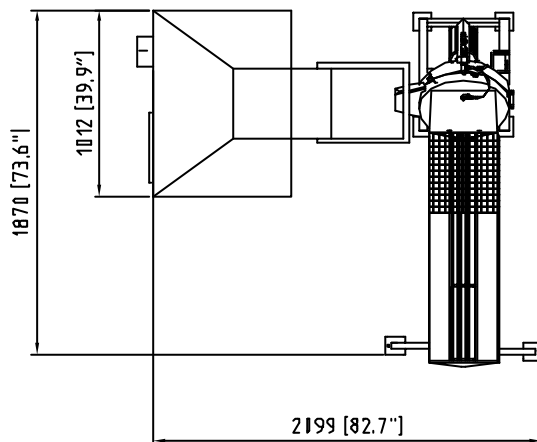
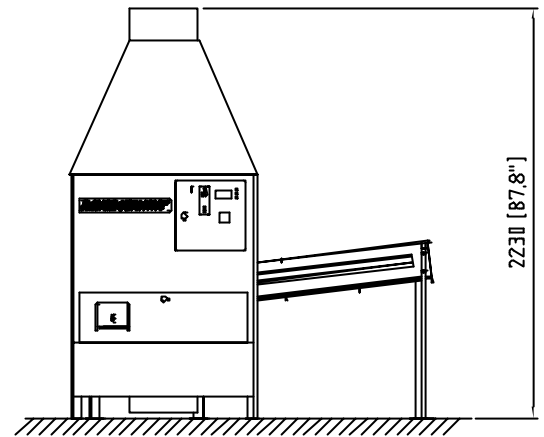
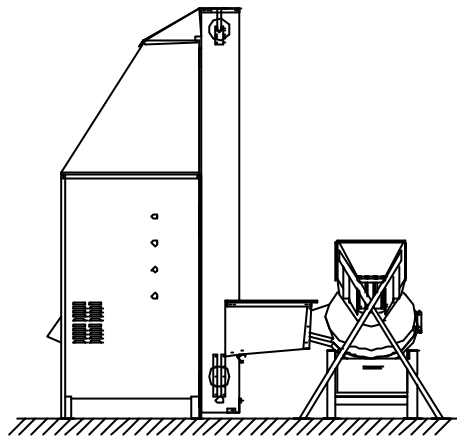

ELEVATOR

CAPACITY	500 BALLS/MIN
MOTOR	0.18 KW
VOLTAGE	230 V, 50 HZ

BALL DISPENSER

HOPPER CAPACITY	12 000 BALLS
SETTINGS	1-999 BALLS
MOTOR	17W AND BW
VOLTAGE	230 V, 50 HZ
WEIGHT	96 KG
DELIVERY CAPACITY	500 BALLS/MIN

BALL WASHER

HOPPER CAPACITY	1,000 BALLS
WASHING CAPACITY	400 BALLS/MIN
MOTOR	1.55 KW
VOLTAGE	230 V, 50 HZ
PLUMBING CONNECTION	R 1/2"
WATER CONSUMPTION	4 L/MIN