

# RANGE SERVANT®

<http://www.rangeservant.com>

## BALL WASHER 1950 AND PRE-SOAK WASHER 3600

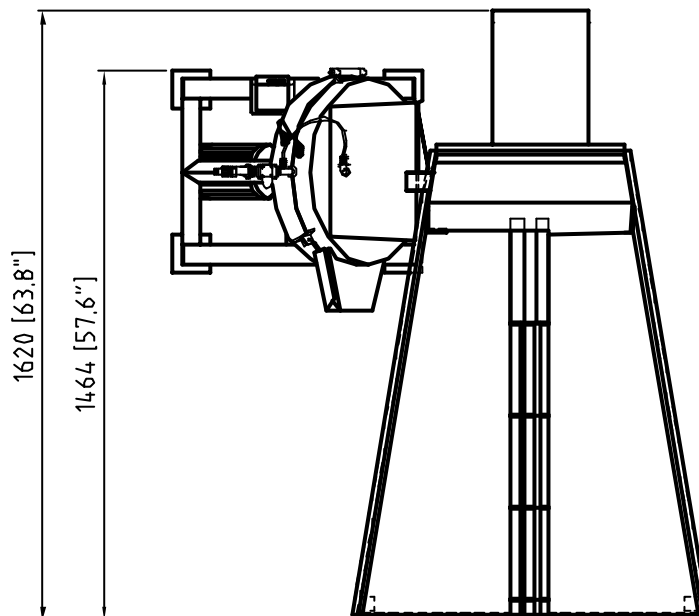
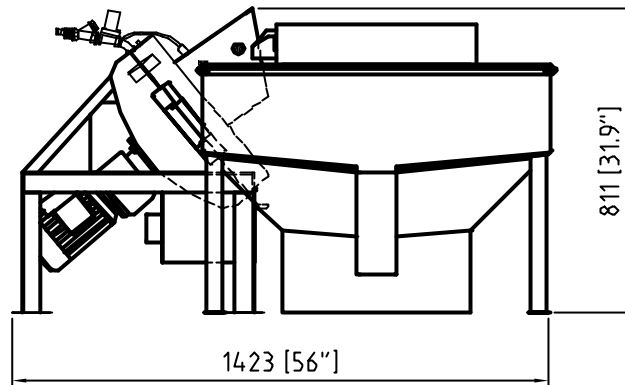

<b>BALL WASHER 1950 AND PRE-SOAK WASHER 3600</b>			
WASHING CAPACITY		400 BALLS/MIN	
<b>PRE-SOAK WASHER 3600</b>		<b>BALL WASHER 1950</b>	
HOPPER CAPACITY	3,600 BALLS	MOTOR	0,55 KW
MAXIMUM WATER VOLUME	240 L	VOLTAGE	220 V, 50 HZ
NET WEIGHT	XX IB	PLUMBING CONNECTION	R 1/2"
VOLTAGE	230 V, 50 HZ	WATER CONSUMPTION	4 L/MIN
MOTOR	55 W		