



ENGLISH

RANGE SERVANT[®]

<http://www.rangeservant.com>

USER'S MANUAL

FOR

DRIVE MODULE



CONTENTS

<u>1</u>	<u>General information</u>	4
1.1	Preface	4
1.2	EC Declaration of Conformity	5
1.3	Description	6
1.3.1	Drive Module with Ball Picker	6
1.3.2	Ball Management System	6
1.4	Identification	6
1.5	Technical specifications	7
<u>2</u>	<u>Safety</u>	9
2.1	General	9
2.2	Conformity with mandatory requirements	9
2.3	Remaining hazards	9
2.4	Authorised use	10
2.5	Unauthorised use	10
2.6	Emergencies	10
2.6.1	Fire	10
2.7	Operational reliability	10
<u>3</u>	<u>Handling</u>	12
3.1	Necessary qualifications	12
3.2	Preparations	12
3.3	Start	13
3.4	Driving	13
3.5	Stop	13
<u>4</u>	<u>Design and function</u>	15
4.1	General	15
4.1.1	Main components	16
<u>5</u>	<u>Maintenance</u>	18
5.1	General	18
5.2	Periodical maintenance	18

5.2.1	Maintenance intervals and instructions	18
5.3	Fault analysis and corrective measures	19
5.3.1	General	19
5.3.2	Fault analysis	19
<u>6</u>	<u>Installation</u>	<u>20</u>
6.1	Factory test and adjustment	20
6.2	Unpacking and assembly	20
<u>7</u>	<u>Spare parts</u>	<u>20</u>
7.1	Drive module	21
7.2	Engine compartment, HONDA 13HP	23
7.3	Engine compartment, Briggs & Stratton 18HP	25
7.4	Instrument panel	27
<u>8</u>	<u>Retailers and representatives</u>	<u>28</u>
8.1	Head Office	28
8.2	Your Sales Representative	28

Title:	br01drivenhet-e.doc
Prepared by:	Johan Carlsson
Date:	2002-08-08
Number of words:	4299
Version:	43

1 General information

1.1 Preface

We would like to congratulate you to your new Range Servant machine. You have made a good choice! You have not only selected an excellent drive module with modern technology demanding a minimum of maintenance; you have also chosen high quality. Quality that is assured by us thanks to modern production technology, careful choice of material and a sense of responsibility in all our employees.

The objective of this manual is to make the user familiar with the machine when used under all kinds of circumstances and for various kinds of tasks. The manual contains all the necessary drawings and diagrams concerning commissioning, maintenance, inspection, function tests and repair of the machine as well as any other useful information, in particular information relating to safety.

Read through and understand the User's Manual before you take the machine into service. If these instructions are not followed, persons using the machine might be injured or the equipment itself damaged. In many cases, following the instructions is a necessary condition for Range Servants' warranty to be applicable. Each person handling the machine must read these instructions.

No part of this publication may be reproduced without the written authorisation of Range Servant.

The machine has a one year guarantee. Study the guarantee certificate carefully and keep it in a safe place. If you have any questions, or if problems should arise, please contact your Range Servant representative.

ONE YEAR GUARANTEE

Range Servant AB hereby offers a guarantee of one year from the date of shipment from the factory on material and function of the RANGE SERVANT product specified below. This engagement applies to repaired or replaced components for a period of three months. This undertaking only applies to the original purchaser. Furthermore, it is limited to the components that the manufacturer finds to be faulty when inspected. Repairs or replacement of components shall be carried out by a representative appointed by the manufacturer. The manufacturer further guarantees that the equipment supplied corresponds to the product description issued. **THE UNDERTAKINGS SPECIFIED IN THIS AGREEMENT CONSTITUTE THE MANUFACTURER'S SOLE OBLIGATION TOWARDS THE PURCHASER. THE MANUFACTURER DECLINES ALL RESPONSIBILITY FOR ANY FORM OF PROMISE OUTSIDE THE FRAMEWORK OF THIS GUARANTEE CERTIFICATE** The manufacturer also declines all responsibility for promises that might have been made by a third party in conjunction with the sale. The guarantee contract does not apply to equipment that has been repaired or has had components replaced by persons/companies not authorised by the manufacturer. The manufacturer's guarantee is void if equipment has been incorrectly used, damaged by lack of maintenance / accident or has not been handled in accordance with the written user's manual supplied on delivery. Finally, the manufacturer is exempted from financial responsibility for any kind of injury which might arise in conjunction with the sale and repair of equipment, and from injury suffered by third parties in conjunction with use of the product.

1.2 EC Declaration of Conformity

In accordance with the Machine Directive 89/392/EEC, annex IIA.

The Manufacturer: **RANGE SERVANT[®]**
Range Servant AB
Skallebackavägen 11
SE- 302 41 HALMSTAD
Sweden

The Representative:

(To be filled out by a representative established within the EU)

.....
Company

.....
Address

.....
Telephone

Declare that:

.....
Machine

.....
Type

.....
Serial no., manufacturing no. etc

A) is in conformity with Council Directive 89/392/EEC of 14 June 1989 concerning approximation of the laws of the Member States relating to machines in particular as referred to in Annexe I to this Directive concerning essential health and safety requirements in connection with the design and manufacture of machines, as amended by Council Directive 91/368/EEC of 20 June 1991 on the amendment of Directive 89/392/EEC concerning approximation of the laws of the Member States relating to machines;

B) (if applicable)

is manufactured in accordance with the following regulations, directives etc.:.....

C) (if the requirements under A have been fulfilled)

that the harmonised standards 292-1, 292-2 and 292-2A (or parts thereof) have been applied

D) (if applicable)

is manufactured according to the following national standards and technical specifications:.....

Halmstad,

.....
Date

Jordan Knez
President

.....
Signature

1.3 Description

1.3.1 Drive Module with Ball Picker

The Range Servant Drive Module is light and easy to manoeuvre. Its turning radius is exceptionally narrow due to the fact that the drive module rests on one single combined driving/steering wheel. Its design is elegant and very robust. Thanks to its lightness it does not damage the range.

The driver's seat is very comfortable, and adjustable according to the driver's wish. A well-sized window up front allows for good visibility. The driver is well protected by heavy-duty nylon mesh and wire doors on both sides, which means that the ball picker can be used even when the driving range is in use.

1.3.2 Ball Management System

Range Servant deliver complete, flexible ball management systems adaptable to any kind of driving range requirements – the Ball Management System. The Ball Dispenser will be combined with the work-efficient, environment-friendly Ball Washer. The Elevator, Conveyor Belt and Blower ensure the transport of clean, undamaged balls from the Washer to either one single Ball Dispenser or to several, according to the installation. To complete the circuit and to reduce manual work to a minimum, the system also includes the Ball Picker picking up the used balls from all over the driving range.

By applying our extensive know-how to the specific problems of each driving range we are able to offer tailor-made solutions.

1.4 Identification

When contacting Range Servant, please identify your machine with the help of the information contained in the identification plate. The identification plate is well visible and firmly attached to the machine and contains the following information:

- Name and address of the manufacturer
- CE-marking
- Designation of series or type of machine
- Serial no., if any
- Year of manufacture

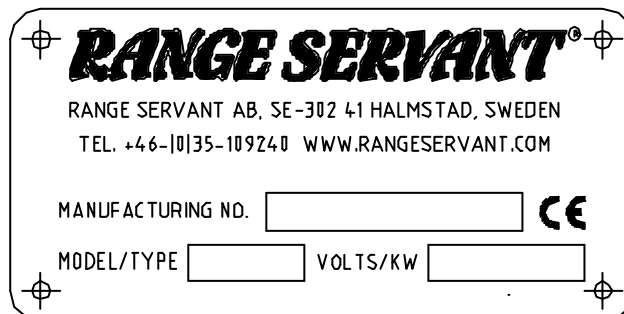

Fig. 1: Product identification plate

1.5 Technical specifications

General	
Max speed [km/h] /([miles/h])	18 (11)
Tyre pressure [kg]	1.5
Dimensions:	
Height [mm] /([in])	1800 (70.7)
Width [mm] /([in])	1000 (39.4)
Length [mm] /([in])	2700 (106.3)
Weight, without ball picker [kg]	240
Combustion engine:	
Capacity [hp] [Honda/ Briggs & Stratton]	13/ 18
Motor oil	SAE 10/40
Fuel volume [l]/([gal]) [Honda/ Briggs & Stratton]	6.5/ 8.5 (1.7/ 2.2)
Fuel type	UNLEADED 95
Hydraulics:	
General:	
Hydraulic oil type	Shell Naturelle HF-E
<i>The quality of the oil will impair considerably if it is mixed with other oils. Rinse the system once when changing from another oil.</i>	or another oil that meets the requirements of SS155434BV46
Hydraulic oil volume [l] /([gal])	16 (4.2)
Normal operating temperature for oil [°C] /([°F])	+50 (+122)
Hydraulic motor:	
Hydraulic pump:	
Hydraulic oil pressure, continuous [bar] /([psi])	150 (2175)
Electric system:	
Control voltage [V, DC]	12
Operating Conditions:	
Operating Temperature [°C] /([°F])	- 10 - + 50 (+14- +122)

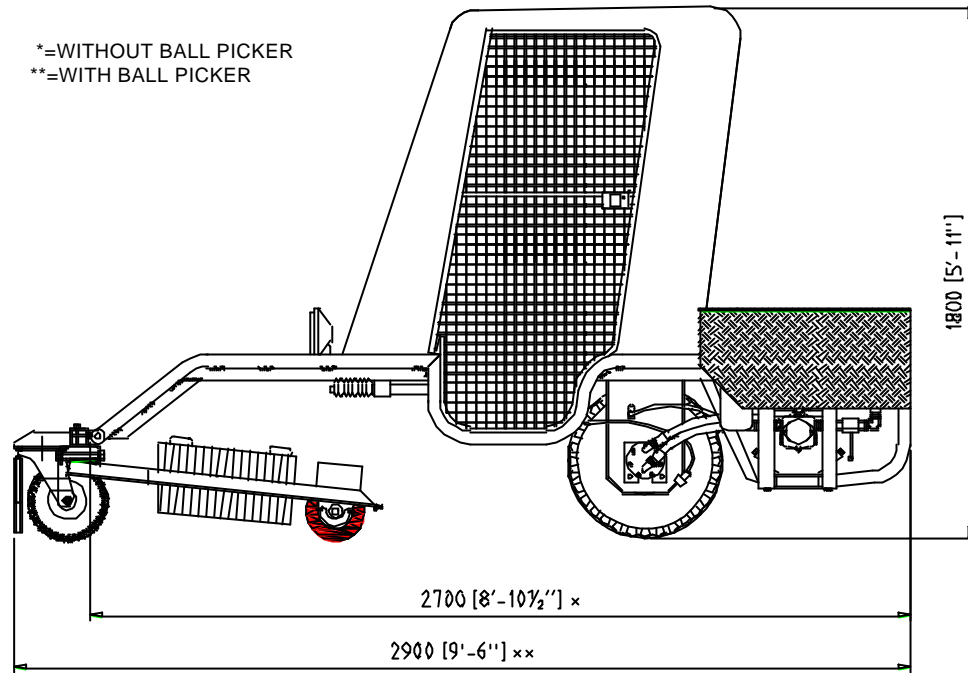

Fig. 2: Drive module with ball picker.

The level of airborne noise has been measured for an identical machine under normal operating conditions. The values indicate the sound pressure level at the driver's seat.

Sound pressure

HONDA 13hp:

Sound pressure at the driver's seat (dB, A)	83
Sound pressure at the driver's seat (dB, Peak)	84

Briggs & Stratton 18hp:

Sound pressure at the driver's seat (dB, A)	XX
Sound pressure at the driver's seat (dB, Peak)	XX

The manufacturer reserves the right to make changes without prior notice.

Patented: : SE 8902762-7, US 5105608, FR 90850275.0, GB 90850275.0, DE 69007373.9, CA 2022788

2 Safety

2.1 General

Safety measures are a combination of measures taken by the manufacturer when designing and building the machine and measures that have to be taken by the user.

The machine has been designed to function, as far as possible, according to its intended purpose and in such a manner that configuration and maintenance can take place without any hazards to the operator, provided such work is carried out according to the instructions laid down in the User's Manual.

The objective of the safety measures is to eliminate all accident hazards during the operational life of the machine including the assembly and dismantling of the machine, even hazards caused by such abnormal circumstances as can be anticipated.

Accessories and spare parts that have not been approved by Range Servant can lead to personal injuries and/or equipment damage and affect the operational reliability of the machine. For the sake of safety you should therefore exclusively use accessories and original Range Servant spare parts recommended by Range Servant. Such accessories and spare parts are specially intended for the machine and are approved by us with regard to safety.

All Range Servant dealers keep accessories and spare parts at your disposal along with competent advice. They also have the technical qualifications necessary for installing your machine and are informed about what technical changes are authorised.

Damage caused through the use of accessories and spare parts not approved by Range Servant and damage caused by unauthorised technical modifications are not covered by the guarantee.

2.2 Conformity with mandatory requirements

The Range Servant ball management machines fulfil the personal safety requirements of the EU Machine Directive 89/392/EEC as amended by Directives 91/368/EEC, 93/44/EEC and 93/68/EEC, with a special reference to Annex I of the Directive concerning essential health and safety requirements in connection with the design and manufacture of machines, as amended by Directive 91/368/EEC. Furthermore the harmonised standards 292-1, 292-2 and 292-2A (or parts thereof) have been applied.

The electrical equipment fulfils the safety provisions laid down in the EU low voltage directive LVD 73/23/EEC, as amended by directive 93/68/EEC.

2.3 Remaining hazards

There are warning signs serving as a reminder and warning to the user of any remaining hazards, i.e. hazards that could not be eliminated, or sufficiently minimised, by the design and against which technical safety measures do not provide complete, or sufficient, protection. The warning signs are worded in the local language and, upon request, in the language understood by the respective operator.

The signs are yellow with black characters and big enough to be readable from a distance of three meters.



- The drive module is liable to tip sideways if not connected to the ball picker.
- The machine risks overturning when driven up and down slopes. Always drive slowly, in a straight line upwards or downwards – never obliquely.



- Changes to the mechanic or electric system may only be carried out in consultation with Range Servant.



Remember to pull the handbrake, switch off the engine and remove the starter keys before:

- manually emptying the ball picker baskets
- carrying out repairs/maintenance.



If the ball picker is equipped with an automatic basket emptying device, the corresponding control equipment must be activated from the driver's seat and only when the driver has full visibility.

2.4 Authorised use

The machine may only be used on driving ranges as a means to propel or move the Range Servant Ball Picker.

The machine may only be operated according to the instructions contained in the User's Manual.

2.5 Unauthorised use

The machine must not be used on public roads. Not even in its capacity as a means to propel or move the Range Servant Ball Picker. The machine is not intended for the transport of passengers.

Using accessories or spare parts not recommended by Range Servant might cause personal injury and/or equipment damage and affect the operational reliability of the machine. For safety reasons, use only those components that have been recommended by us. They are intended for your machine, they have been chosen for safety reasons and they are approved by the manufacturer.

Damage caused by the use of accessories and spare parts not approved by Range Servant or damage caused by unauthorised technical changes are not covered by the guarantee.

2.6 Emergencies

2.6.1 Fire

In the event of fire, water shall be used as an extinguisher, except if the fire is located in the electric equipment, where a carbon dioxide extinguisher must be used.

2.7 Operational reliability

For trouble-free operation and long service life, the instructions below should be followed:

- Place the machine under roof when not in use.

- Follow the maintenance instructions laid down in the section “Maintenance”.
- Never strain the machine by loading the Ball Picker with more balls than recommended. The loading capacity for your machine is stated in the technical specifications.
- When cleaning the Drive Module, never spray water directly onto the electric components.

3 Handling

3.1 Necessary qualifications

The technical design and function of the machine is such that the person carrying out service and maintenance work must have the necessary qualifications. He is required to have attended a documented training course consisting of the study of the User's Manual, at the end of which he must have well understood its contents.

If the person is absent from work for more than three months, training must be renewed.

3.2 Preparations

Remember to:

- Put the disengagement valve (part no. 505050) as shown at A in the adjoining picture.

If the machine is not to be used for a certain time or you want to put it in neutral, put the valve in the opposite position to that shown in the picture.

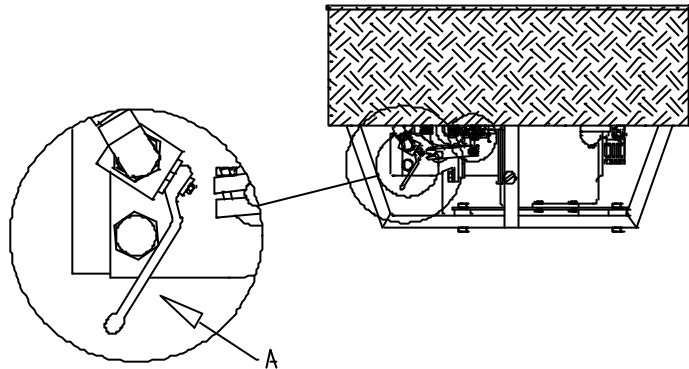

- Read and follow the engine instruction manual.
- Fill the fuel tank with 95 octane unleaded petrol or 96 octane regular petrol.

Do **not** mix oil with the petrol!

- Check the oil level in the hydraulic oil tank by unscrewing the cap. The cap has an integrated oil dipstick.

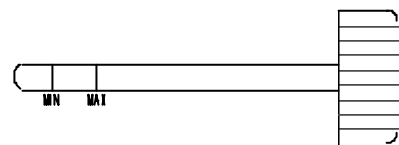

- Adjust the driver's seat:

Spring firmness is adjusted with the lever (A).

The back is adjusted with the knob (B).

The distance to the steering wheel is adjusted with lever (C) under the seat.

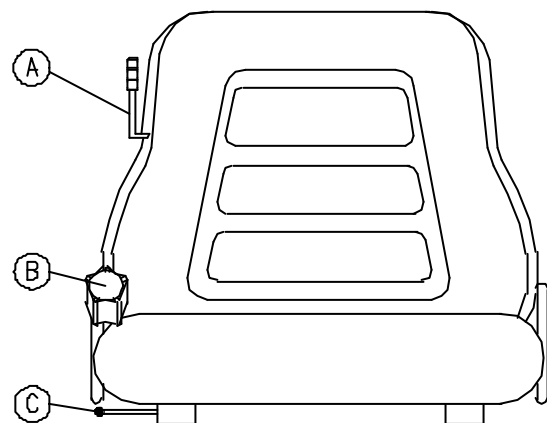

3.3 Start

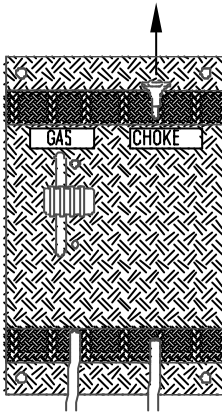

- If the engine is cold, pull out the choke.
- Set the throttle control to the middle setting.
- Turn the starter key to the starting position and release as soon as the vehicle starts. The choke can be pushed in after the engine has been running for about half a minute.

3.4 Driving

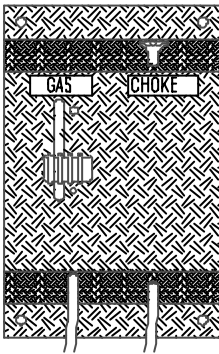

- Under normal driving, the throttle should be set at max. $\frac{3}{4}$ of full-throttle.

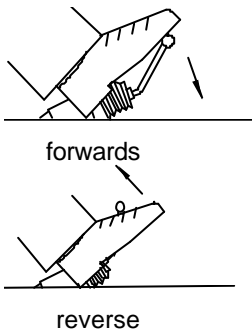

- Forwards: Press down the foot pedal.
- Reverse: Lift foot pedal.

3.5 Stop

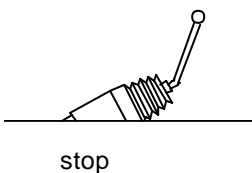

- Stop: Release foot pedal.

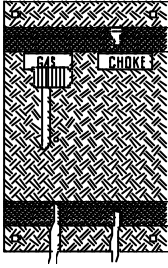

- Reduce the throttle to zero.
- Switch off the ignition.

Attention! Remember to switch off the lights. The ignition switch does not disconnect the current supply to the headlights.

4 Design and function

4.1 General

The Drive Module is an easily operated, uncomplicated device used for propelling and moving the Ball Picker. Thanks to the ingenious design of the driving wheel, the turning radius of the Drive Module is very small and the stress on Ball Picker and other components reduced.

The driving wheel which is mounted in a U-shaped wheel holder at the rear of the drive module frame is used as well for propelling as for turning the unit. This is achieved with the help of a hydraulic motor, mounted at the hub of the driving wheel and connected with hoses through a three-way disengagement valve and a hydraulic oil tank to a hydraulic pump driven by a combustion engine. The Drive Module also includes a driver's compartment with a seat, a foot pedal for manoeuvring the disengagement valve and a manually operated brake.

Due to the fact that the Ball Picker is placed between the supporting wheels at the front and the driving wheel at the rear of the Drive Module, the peripheral speed at each turn is greatly reduced which allows for good work efficiency.

The Ball Picker consists of a beam to which a number of ball picking sections are fastened. The beam rests on several spaced out supporting wheels. The fastening device of the Drive Module is placed at the centre of the beam. The ball picking sections pivot in relation to the beam.

4.1.1 Main components

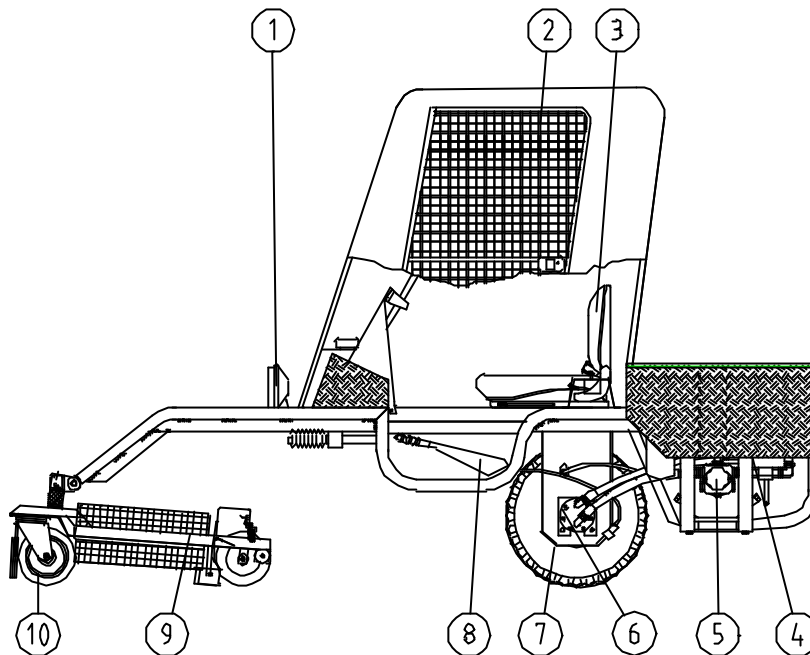

Fig. 3: Drive module from the side

Pos.	Designation
1	Headlights
2	Driver's compartment
3	Seat
4	Combustion engine
5	Hydraulic pump
6	Hydraulic motor
7	Driving wheel
8	Hand brake
9	Ball picker
10	Supporting wheels

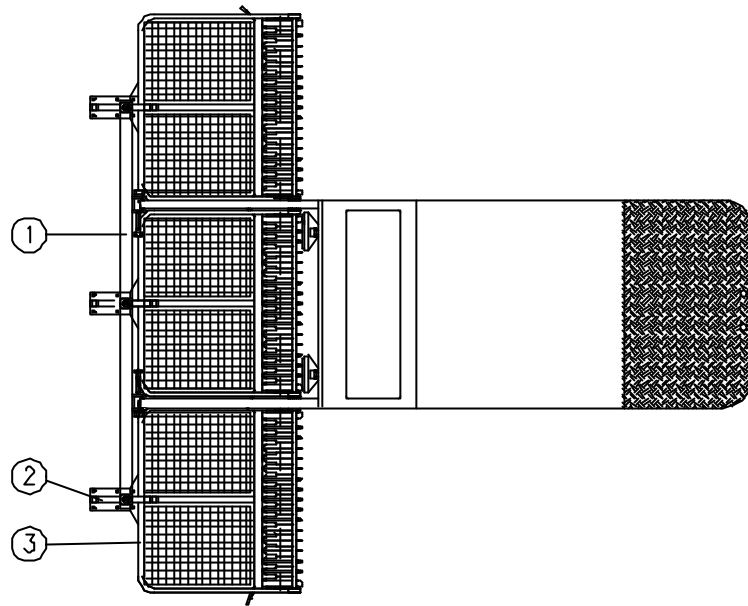

Fig. 4: Drive module from above

Pos.	Designation
1	Ball picker beam
2	Attachment for supporting wheels
3	Ball pick section

5 Maintenance

5.1 General

Range Servant will provide accessories and original spare parts together with competent advice.

Maintenance carried out correctly ensures maximum service life and reliable operation. Any malfunctions will be detected at an early stage and are therefore easily corrected. Regular maintenance minimises defects and equipment breakdown.

The following maintenance instructions only refer to the most common problems and their causes.

5.2 Periodical maintenance

5.2.1 Maintenance intervals and instructions

Maintenance intervals:

1. After 100 operating hours
2. Daily
3. Once every 100 operating hours
4. Once every season or once every 500 operating hours

Maintenance intervals and instructions:		1	2	3	4
1	Drive module:				
1.1	If artificial manure is used on the driving range, we recommend that the machine be thoroughly cleaned. Switch off the engine, remove grass and debris and rinse with normal clean water. This is to avoid corrosion on the interior components of the machine.			X	
1.2	Lubricate the wheel fork bearing by lubricating the nipple (part no. 50 0610) in the engine compartment.			X	
1.3	Lubricate the slide bearings at the front where the ball picker is attached (part no. 50 0280)			X	
1.4	Lubricate linking arms with ordinary lubricating oil.				X
1.5	Lubricate the throttle wire (part no. 50 0970), the gearshift wire (part no. 50 1060) and the choke wire (part no. 50 0940).				X
2	Hydraulics:				
2.1	Replace the hydraulic oil filter (part no. 50 6030).	X			
2.2	Check the hydraulic oil level and top up if necessary. Check the level by unscrewing the cap of the oil tank and use the integrated oil dipstick.		X		
3	Combustion engine:				
3.1	Refer to the engine instruction manual for maintenance instructions.				

5.3 Fault analysis and corrective measures

5.3.1 General

The drive module is very reliable but problems may nevertheless arise for various reasons. When analysing the fault, start by defining the fault according to function, i.e. find out whether the fault concerns the mechanical, hydraulic, pneumatic or electric equipment.

5.3.2 Fault analysis

The below chart will help you to localise the fault:

Type of fault	Symptom	Checks/Corrective measures
Mechanical	→ The combustion engine does not start.	→ Refer to the engine instruction manual.
	→ Defects on the mechanical equipment are in most cases detected when checking moving parts for changes such as wear and/or damage.	
Electrical	→ If the trouble has been localised to the electrical equipment, check the voltage at various measuring points to find the defective function/component/connection/cable.	
Hydraulic	→ The hydraulic system is completely or partly without pressure.	→ The disengagement valve is in the wrong position.
		→ Insufficient oil in the tank.
		→ The filter is clogged.
		→ The hydraulic pump is not running.
		→ Insufficient oil in the tank.
	→ Vibrations from the oil pump.	→ Air leakage in the suction line.
		→ Deformed suction line.
	→ Clogged filter.	
	→ Defective hydraulic pump.	
	→ Too low hydraulic pressure.	
	→ Jammed wheel bearings.	
→ The driving wheel does not drive.	→ Oil pump does not run.	
	→ Defective packing between suction and discharge side.	
	→ Worn-out rotor or body.	
→ The oil pump does not run.	→ Worn-out spline socket between combustion motor and hydraulic pump.	

Fig. 5: Fault analysis chart for drive module.

6 Installation

6.1 Factory test and adjustment

The machine is tested and all the relevant parameters adjusted in accordance with the customer's order before leaving the factory.

Our objective when carrying out this final check is to verify that the product corresponds on all accounts to the requirements laid down by the customer when ordering and to prevent defective products from being brought onto the market.

6.2 Unpacking and assembly

- Remove the packaging.
- Connect the drive module to the picker as shown in the adjoining picture.

Attention! The drive module is liable to tip sideways without connected picker equipment.

To prevent the drive module from tipping, you will need the help of two people when connecting the ball picker.

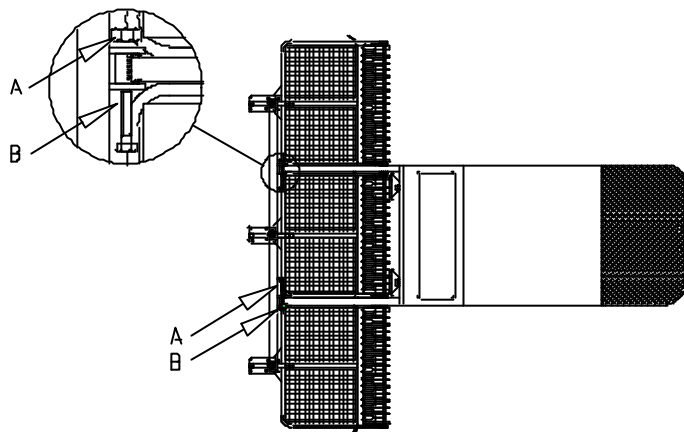

Fig. 6: Connecting the drive module to the picker.

- Fit the baskets in their intended locations.

7 Spare parts

This chapter contains detailed drawings showing the location of the different spare parts. The tables accompanying the drawings contain information about spare parts numbers and designation and the quantity of each spare part installed per unit.

() = Optional accessories are marked with a parenthesis around the digit representing quantity.

- = The alternative marked with "-" depends on the customer's choice of equipment.

7.1 Drive module

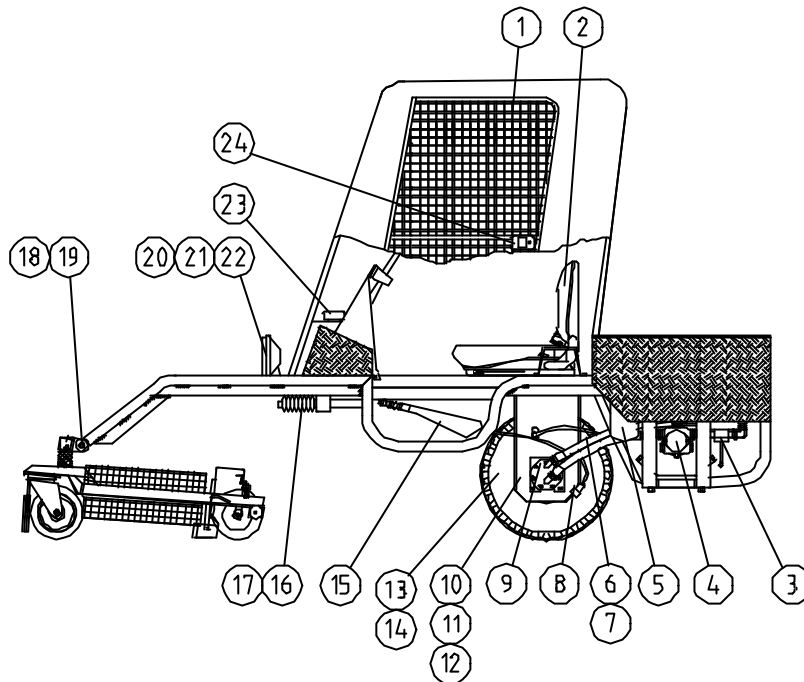

Fig. 7: Viewed from the side.

Pos.	Part no.	Designation	Qty
1	50 3500	Complete cover including O-rings.	1
2	50 0550	Driver's seat	1
3	50 5050	Disengagement valve	1
4	50 6100	Hydraulic oil pump	1
5	50 6030	Oil filter for hydraulic oil pump	1
6	50 5150	Hydraulic hose 1112/840/450188/4527-10-8½	1
7	50 5200	Hydraulic hose 1112/1000/450388/4521-10-8	1
8	50 2400	Handbrake wire	1
9	50 6150	Hydraulic motor	1
10	50 4000	Wheel suspension excluding wheel	1
11	50 4200	Bearings plate, wheel suspension	1
12	50 4210	Roller bearings for bearings plate	20
13	50 4260	Tyre 20"x10"-10	1
14	50 4270	Wheel rim	1
15	50 2300	Handbrake lever	1
16	50 0500	Steering gear	1
17	50 1730	Steering linkage/steering rod	1
18	01 9100	Hexagonal screw M16x100	2
19	02 2600	Nut M16	2
20	50 1320	Headlamps	2
21	50 1330	Headlamp bulbs	2
22	50 1350	Headlamp grille	2
23	50 1630	Tank cap/oil dipstick	1
24	50 3140	Complete door lock, left	1
	50 3141	Complete door lock, right	1

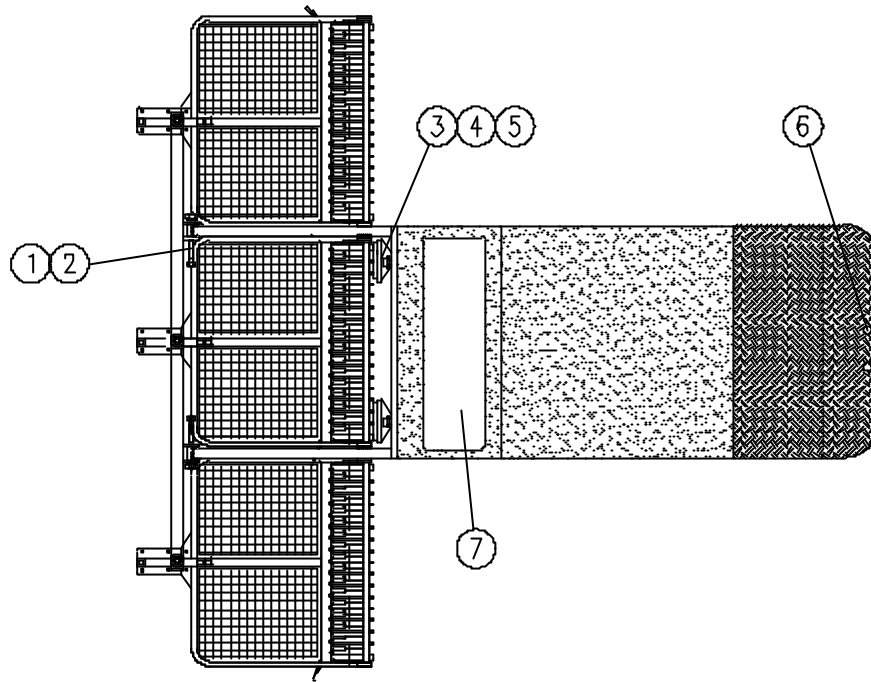

Fig. 8: Viewed from above

Pos.	Part no.	Designation	Qty.
1	01 9100	Hexagonal screw M16x100	2
2	02 1600	Lock nut M16	2
3	50 1320	Headlamps	2
4	50 1330	Headlamp bulbs	2
5	50 1350	Headlamp grilles	2
6	50 1240	Platform lock, RITTAL SZ 2520	1
7	50 3510	Front windscreen, plexiglass	1

7.2 Engine compartment, HONDA 13HP

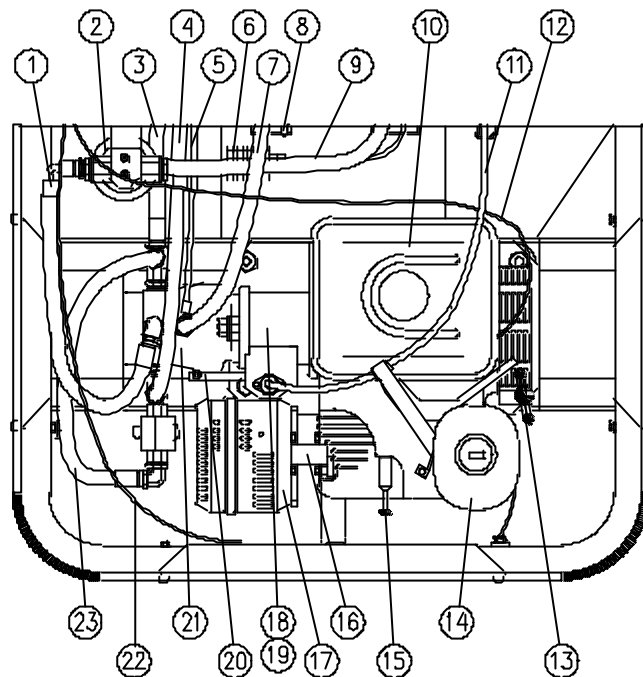

Fig. 9: Engine compartment from above, HONDA 13HP

Pos.	Part no.	Designation	Qty.
1	50 5000	Hose between filter and pump 1112K/650/450188/450388	1
2	50 6030	Oil filter for hydraulic oil	1
3	50 5200	Hose at the rear of the pump – at the bottom of the engine, 1112K/1000/450388/4521-10-8	1
4	50 5150	Hose at the front of the pump – on top of the engine, 1112K/840/450188/4527-10-8½	1
5	50 5250	Hose for engine draining, 1106K/900/4501-4-4/4521-6-4	1
6	50 5450	Charge relay	1
7	50 5400	Hose between oil tank and pump, ½", 1800mm, 2TE-8	1
8	50 0610	Lubrication nipple	1
9	50 6020	Suction hose, ¾", 1.5m	1
10	50 5550	Engine, HONDA 13HP	1
11	50 1060	Gearshift wire	1
12	50 0970	Throttle wire	1
13	50 5580	Starter cord with handle	1
14	50 5560	Air filter	1
15	50 5570	Spark plug	1
16	50 5800	Exhaust pipe	1
17	50 5590	Silencer	1
18	50 5901	Intermediate section	
19	50 6122	Spline socket, pump-engine	
20	50 6300	Gearshift rod	1
21	50 6100	Hydraulic oil pump	1
22	50 0940	Choke wire	1
23	50 5100	Disengagement hose, 1112K/600/450188xdo	1

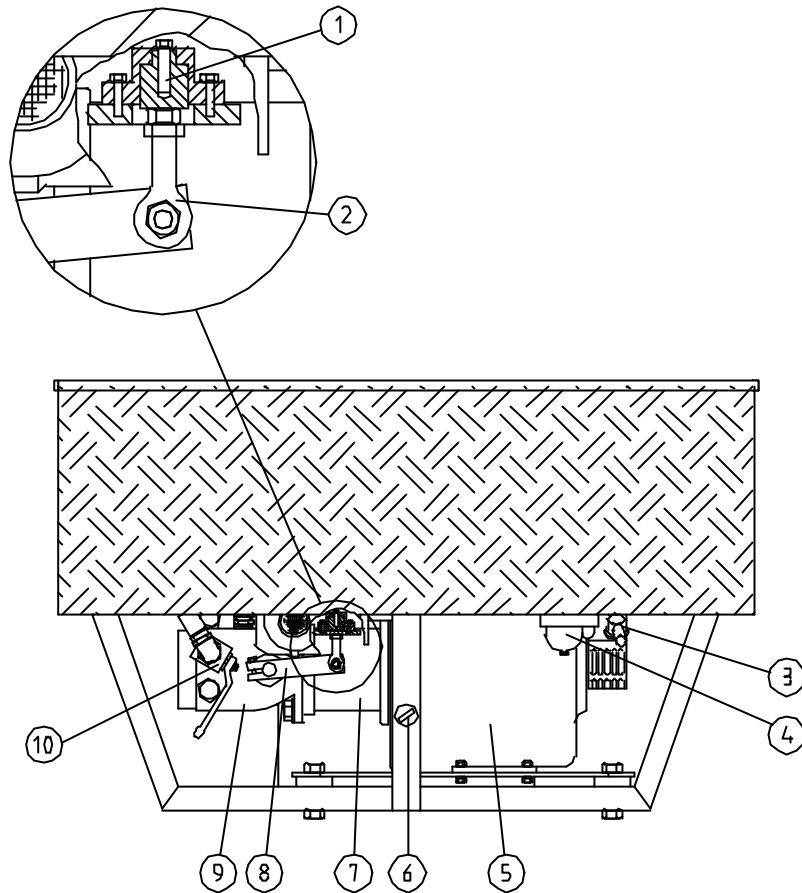

Fig. 10: Engine compartment from behind, HONDA 13HP

Pos.	Part no.	Designation	Qty.
1	50 5660	Bolt and pin	1
2	50 5650	Uniball link	1
3	50 5580	Starter handle including cord	1
4	50 5600	Fuel filter	1
5	50 5550	Engine, HONDA 13HP	1
6	50 5610	Engine oil dipstick	1
7	50 5900	Intermediate section	1
8	50 6300	Gearshift rod	1
9	50 6100	Hydraulic oil pump	1
10	50 5050	Disengagement valve	1

7.3 Engine compartment, Briggs & Stratton 18HP

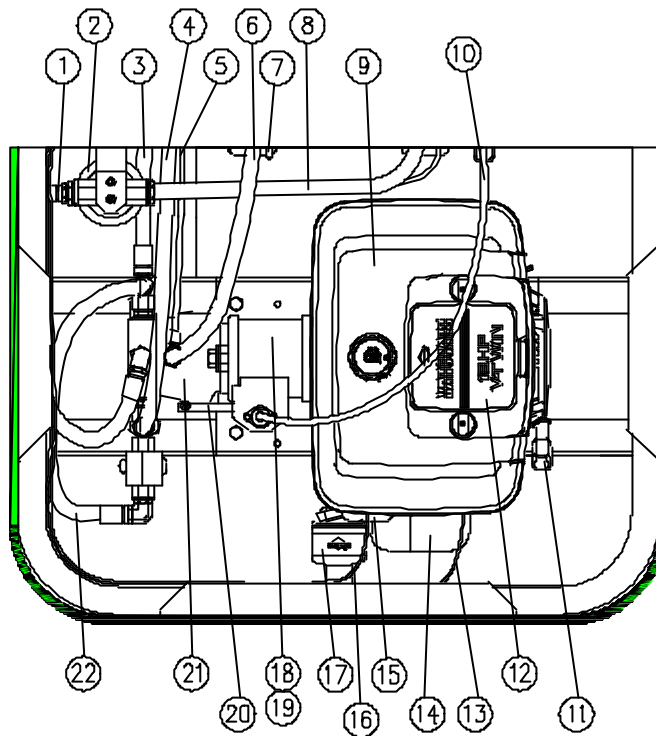

Fig. 11 Engine compartment from above, Briggs & Stratton 18hp

Pos.	Part no.	Designation	Qty.
1	50 5000	Hose between filter and pump 1112K/650/450188/450388	1
2	50 6030	Oil filter for hydraulic oil	1
3	50 5200	Hose at the rear of pump – at the bottom of engine, 1112K/1000/450388/4521-10-8	1
4	50 5150	Hose at the front of pump – on top of engine, 1112K/840/450188/4527-10-8½	1
5	50 5250	Engine draining hose, 1106K/900/4501-4-4/4521-6-4	1
6	50 5400	Hose between oil tank and pump, ½", 1800mm, 2TE-8	1
7	50 0610	Lubrication nipple	1
8	50 6020	Suction hose, ¾", 1.5m	1
9	50 5551	Engine, Briggs & Stratton 18HP	1
10	50 1060	Gearshift wire	1
11	MCA0001	Starter cord reel	1
12	MCA0006	Air filter	1
13	50 0940	Choke wire	1
14	MCA0007	Silencer	1
15	MCA0008	Manifold	1
16	50 0970	Throttle wire	1
17	MCA0005	Oil filter	1
18	50 5900	Intermediate section	1
19	MCA0018	Spline socket, pump-engine	1
20	50 6300	Gearshift rod	1
21	50 6100	Hydraulic oil pump	1
22	50 5100	Disengagement hose, 1112K/600/450188xdo	1

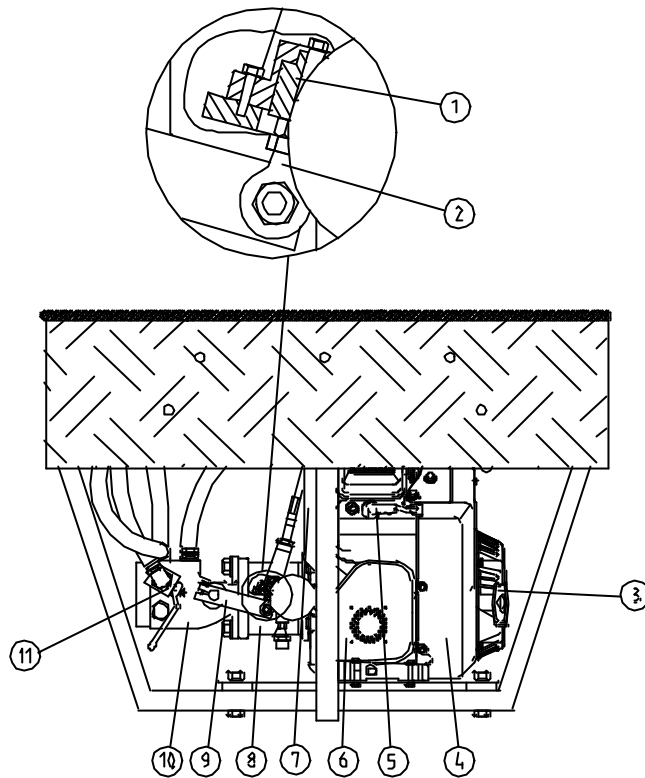

Fig. 12: Engine compartment from behind, Briggs & Stratton 18hp

Pos.	Part no.	Designation	Qty.
1	50 5660	Bolt and pin	1
2	50 5650	Uniball link	1
3	MCA0001	Starter cord reel	1
4	50 5551	Engine, Briggs & Stratton 18HP	1
5	50 5570	Spark plug	1
6	MCA0007	Silencer	1
7	MCA0008	Manifold	1
8	50 5900	Intermediate section	1
9	50 6300	Gearshift rod	1
10	50 6100	Hydraulic oil pump	1
11	50 5050	Disengagement valve	1

7.4 Instrument panel

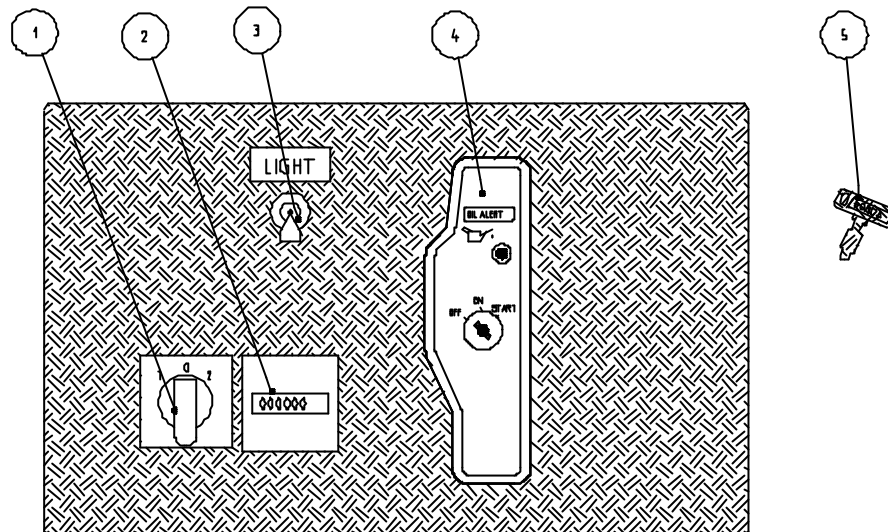

Fig. 13: Instrument panel, HONDA 13HP

Pos.	Part no.	Designation	Qty.
1	93 0519	Reversing Switch, Hydraulic emptying system	(1)
2	50 1900	Engine hour meter	1
3	50 1950	Headlamp switch	1
4	50 1860	Electric starter	1
	50 1865	Ignition lock, HONDA 13hp	1
5	50 1870	Ignition key	1

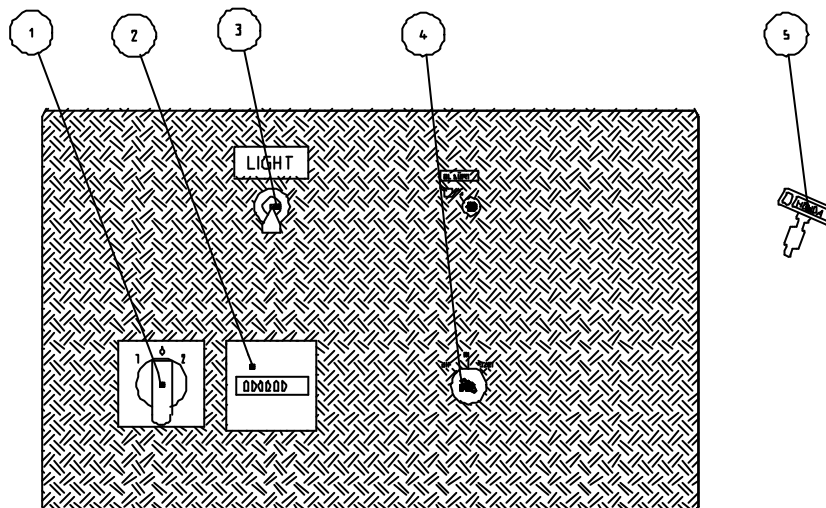

Fig. 14: Instrument panel, Briggs & Stratton 18HP

Pos.	Part no.	Designation	Qty.
1	93 0519	Reversing Switch, Hydraulic emptying system	(1)
2	50 1900	Engine hour meter	1
3	50 1950	Headlamp switch	1
4		Ignition lock, Briggs & Stratton 18hp	1
5	50 1870	Ignition key	1

8 Retailers and representatives

The following list contains all the necessary information concerning the Range Servant representative closest to where you live.

The list is continuously updated on our home page <http://www.rangeservant.com>

8.1 Head Office

Sweden

Range Servant AB

Skallebackavägen 11

302 41 HALMSTAD

Telephone: +46 35 10 92 40

Fax: +46 35 10 82 20

E-Mail: sales@rangeservant.com

8.2 Your Sales Representative

