

# RANGE SERVANT®

<http://www.rangeservant.com>

## DITCH WITH EQUIPMENT

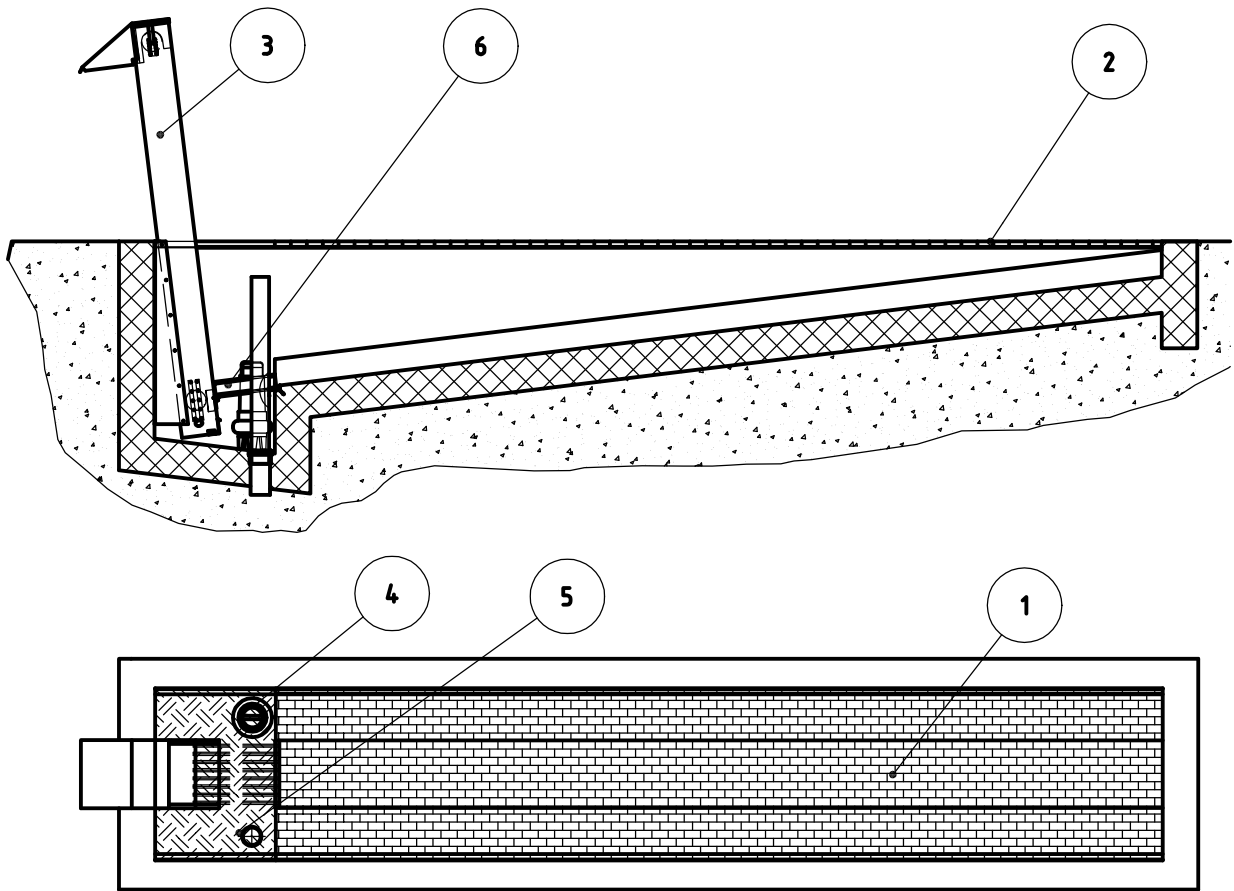

|   |  |  |
|---|--|--|
| 1 | <u>DITCH</u><br>DIMENSION (L x W x H):                           | 5680 x 900 x 1195 MM                                   |
| 2 | <u>UPPER GRID</u><br>DIMENSION (L x W x H):                      | 5000 x 950 x 30 MM                                     |
| 3 | <u>DITCH ELEVATOR</u>  | SEE SEPARATE DRAWING                                   |
| 4 | <u>PUMP</u><br>CAPACITY:<br>SOLID PARTICLES:<br>ELECTRICAL DATA: | 400-600 L/MIN<br>MAX 45 MM<br>3 - 50Hz<br>400V / 4 A Y |
| 5 | <u>DRAINAGE</u><br>DIMENSION (∅, L):<br>REMOVABLE FROM BOTTOM    | 100, 1050 MM   |
| 6 | <u>LOWER GRID</u>  |  |

DITCH ELEVATOR, LOWER GRID AND DRAINAGE IS NOT INCLUDED IN THE PRICE OF THE DITCH.