

RANGE SERVANT®

<http://www.rangeservant.com>

BALL WASHER 1950

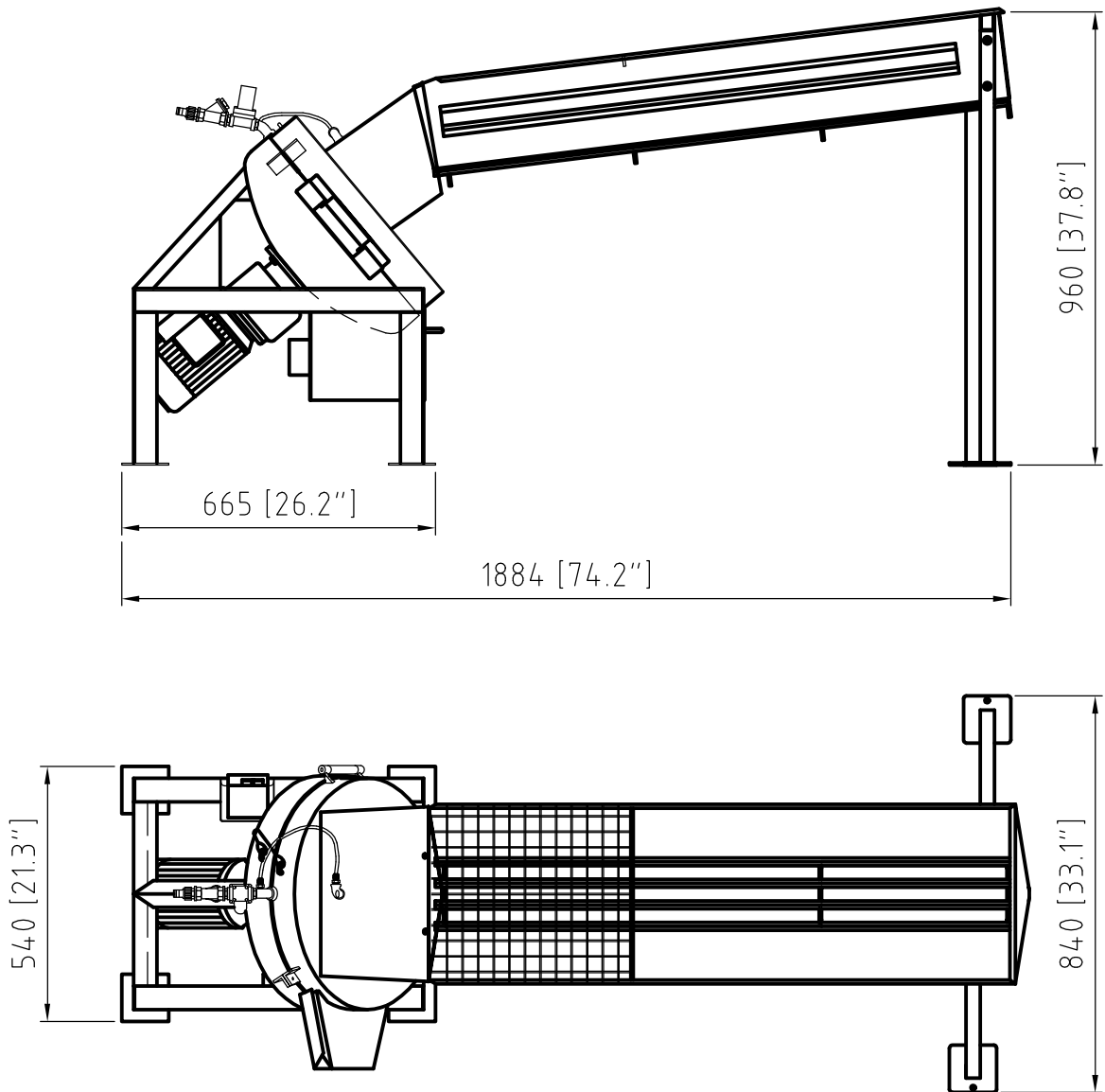

HOPPER CAPACITY	1000 BALLS
WASHING CAPACITY	400 BALLS/MIN
MOTOR	0.55 KW
VOLTAGE	220 V, 50 HZ
PLUMBING CONNECTION	R 1/2"
WATER CONSUMPTION	4 L/MIN
WATER PRESSURE	1,96 - 12 BAR